

SPECIFICATION

Cart Type	2 molds loading, both directions carry-in&out, one pitch movement	
Dolly movement	Drive	Gear motor with brake x2sets
	Speed	Hi-speed 10 m/min ~ Low-speed 2 m/min
	Control	With slow-down stopping by inverter control
Rail	Type	JIS-37k
Mold movement	Driving roller type	
	Drive	Gear motor with brake x2sets
	Speed	Hi-speed 15 m/min ~ Low-speed 3 m/min
	Control	With slow-down stopping by inverter control
Power supply	Power source	AC380V, 3-phase, 50Hz,
Dolly positioning type	Type	Air cylinder driven positioning pin insertion type
Mold fall preventive device	Type	Ejecting knock pin type, lifted by air cylinder
Safety bumper	Type	Bumper Switch
	Position	Front lower and Back lower
Warning light	Revolving warning light Yellow (Illumination at the dolly movement) Revolving warning light Green (Illumination at the mold movement)	
Sensor	Mold transferring slow-down Dolly moving slow-down, Dolly moving stop	

MATSUI Mold Changer System

ROLLER TYPE



Control Panel "TOUCH SCREEN"

FIX MOLD PUSHER TYPE

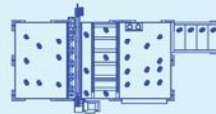

TOP VIEW

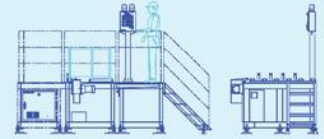

SIDE VIEW

MAIN FEATURES OF MATSUI'S MOLD CHANGER SYSTEM

- Save the production time by speeding up the mold changing cycle time.
- Save the cost of production for safety issue.
- Save manpower in cleaning and operation.
- Reduce costs down for one cycle of molding production.
- MATSUI manufacture the product locally and provide services by MATSUI(ASIA)CO.,LTD.

BANGKOK OFFICE
159 Serm-Mit Tower, 25th Floor, Sukhumvit 21 Rd., North Klongtoey Sub District Wattana District, Bangkok 10110 Thailand
Tel : 0-2261-7512-3, 0-2661-7613-4 Fax : 0-2261-7495

FACTORY
No. 300 Moo 4 Soi 5C Bangpoo Industrial Estate Sukhumvit Rd, Tambol Praksa Amphur Muang, Samutprakam 10280 Thailand
Tel : 0-2324-0216-8, 0-2709-3850-1 Fax : 0-2324-0219

AMATANAKORN OFFICE
68/30-31 Moo 6 T. Donhuaroh A. Muang, Chonburi 20000 Thailand
Tel : 038-453-198-9 Fax : 038-453-200

MATSUI MOLD CHANGER SYSTEM CONCEPT

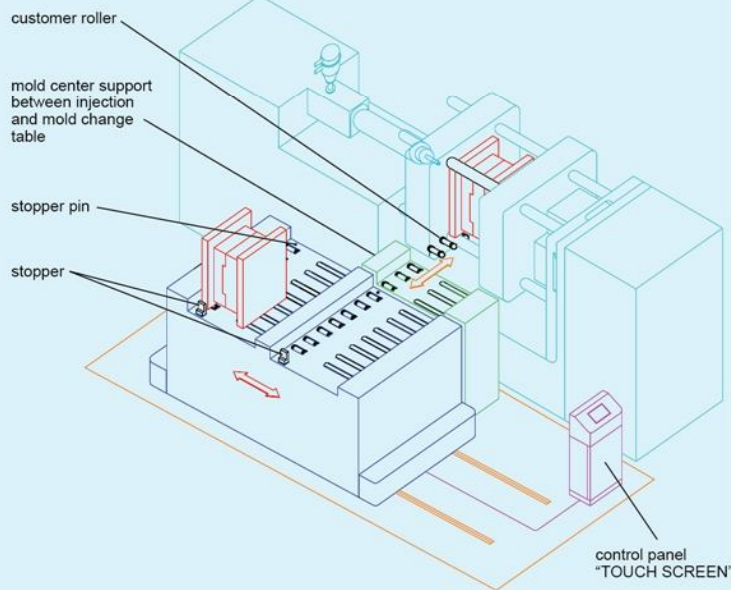

Matsui's Mold Change System "Roller Type"

Mold Change System

ONE SIDE MOLD CHANGE CART "ROLLER TYPE"

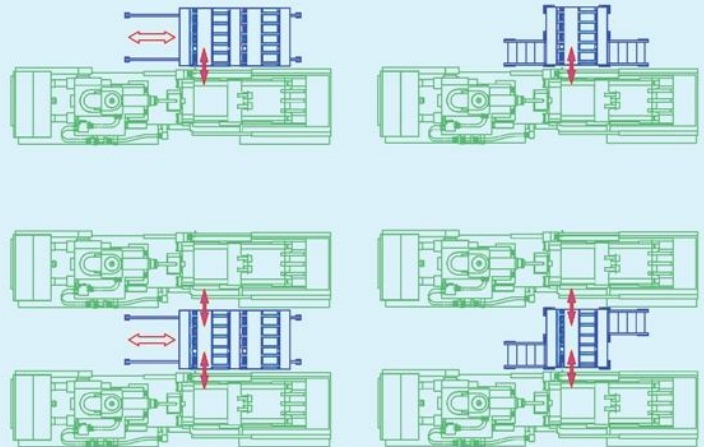

BOTH SIDE MOLD CHANGE CART "ROLLER TYPE"

